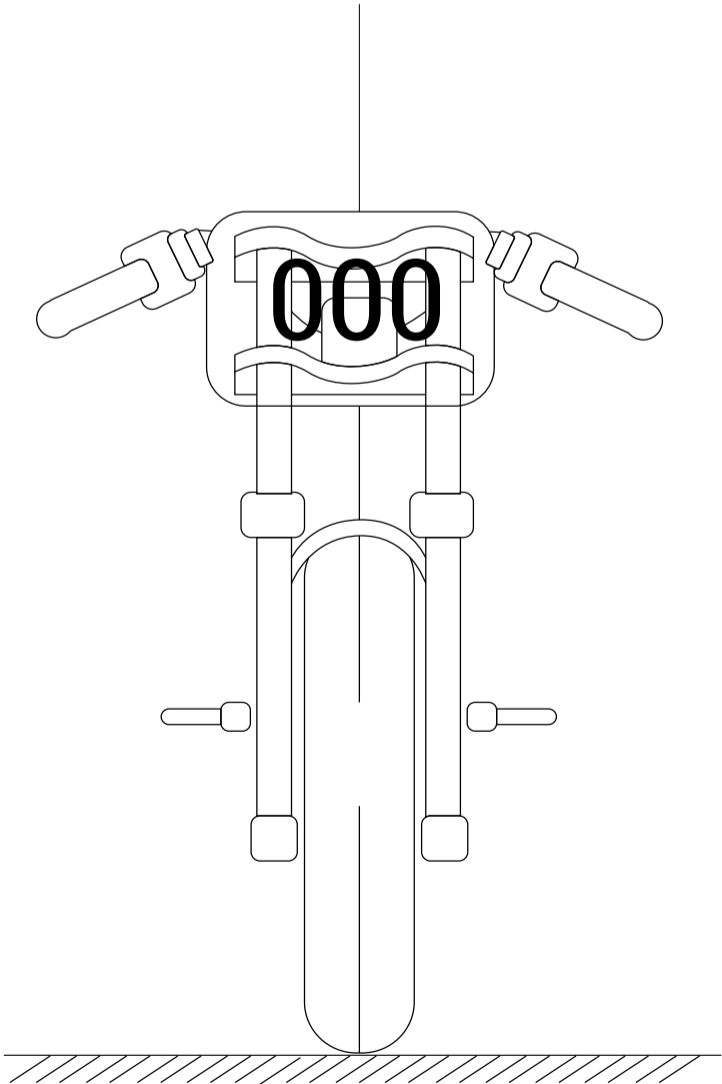
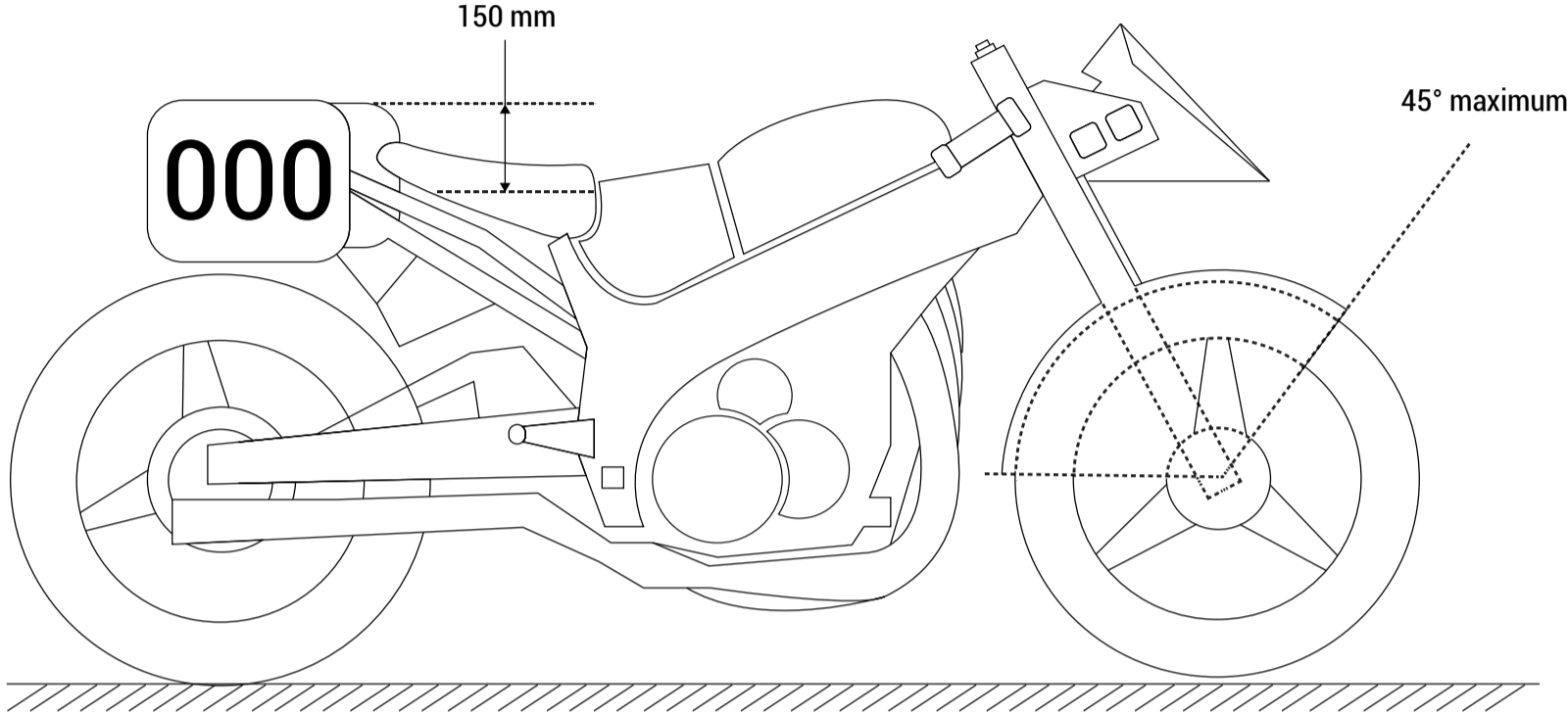

**DIAGRAM A**

NON STREAMLINED

See Art 2.15. & 2.20.



# DIAGRAM B

PARTIALLY STREAMLINED

See Art 2.15.B.

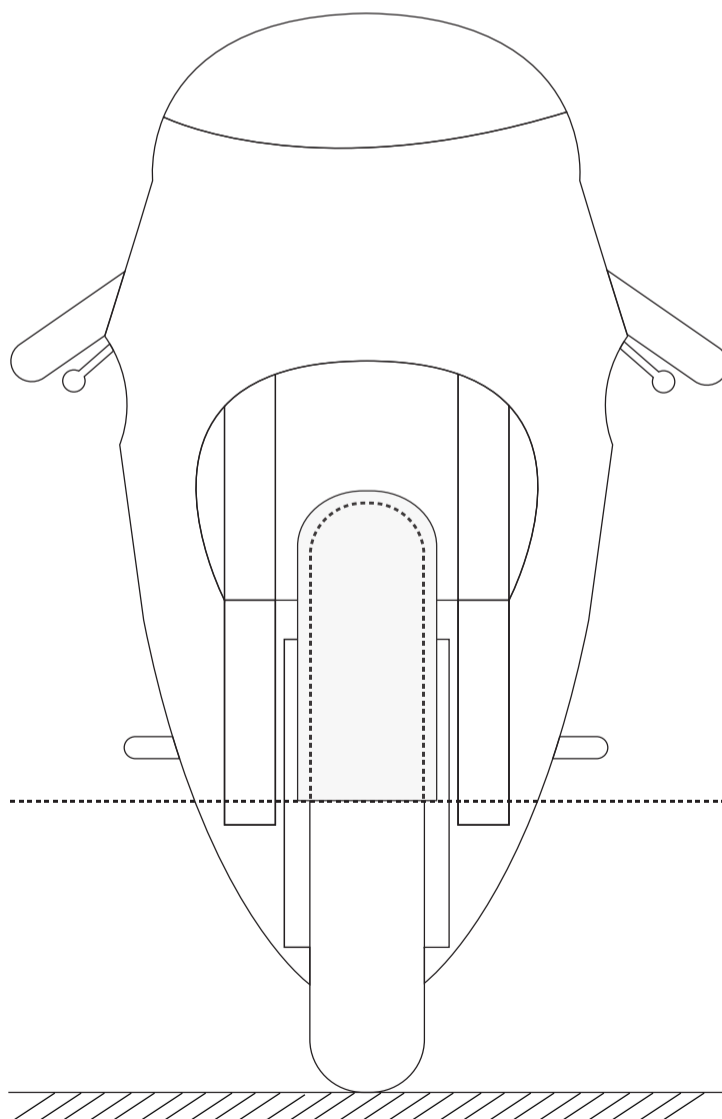
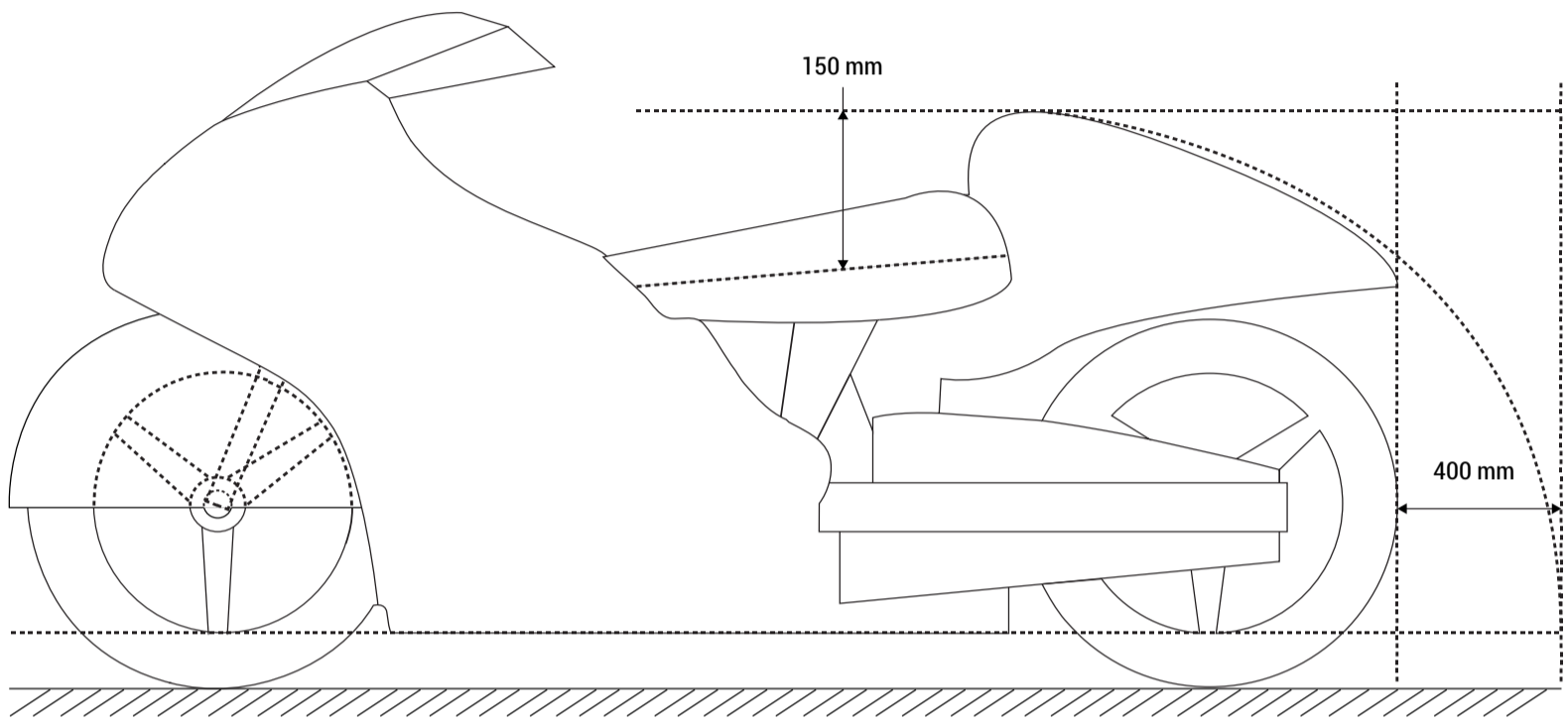
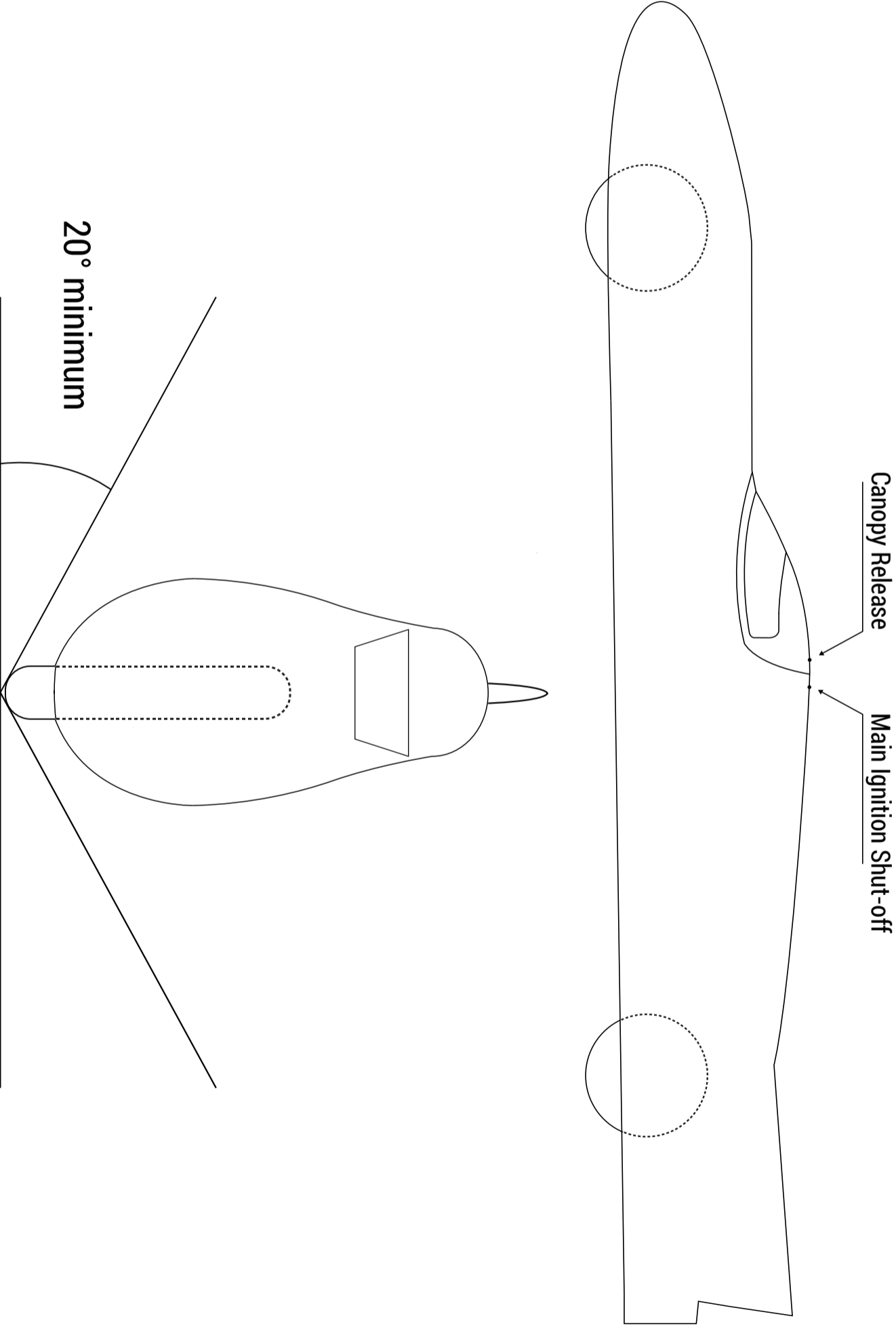
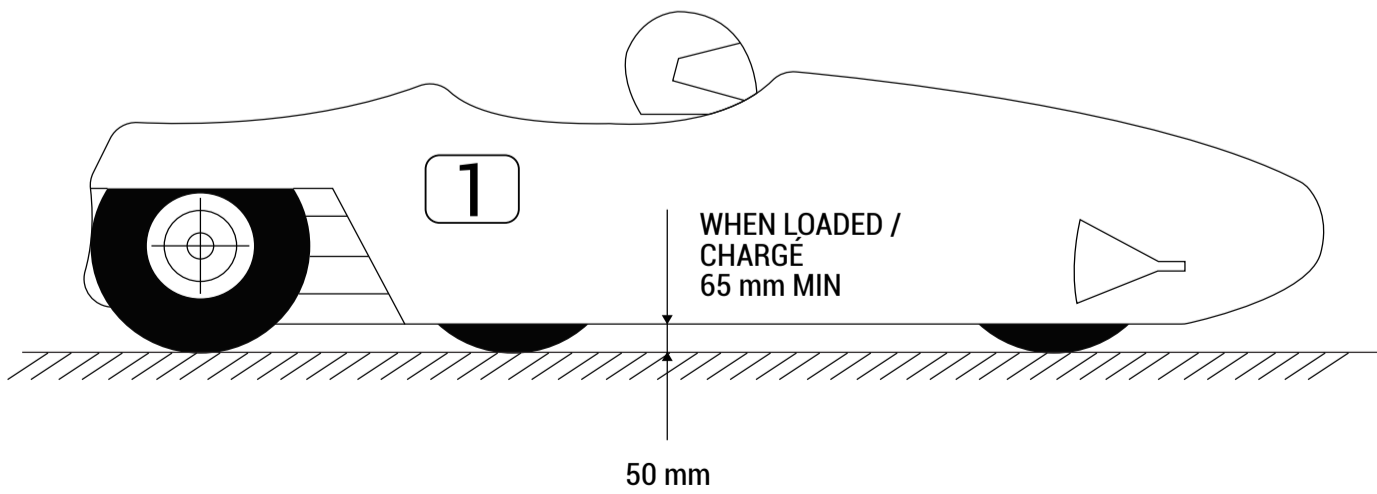
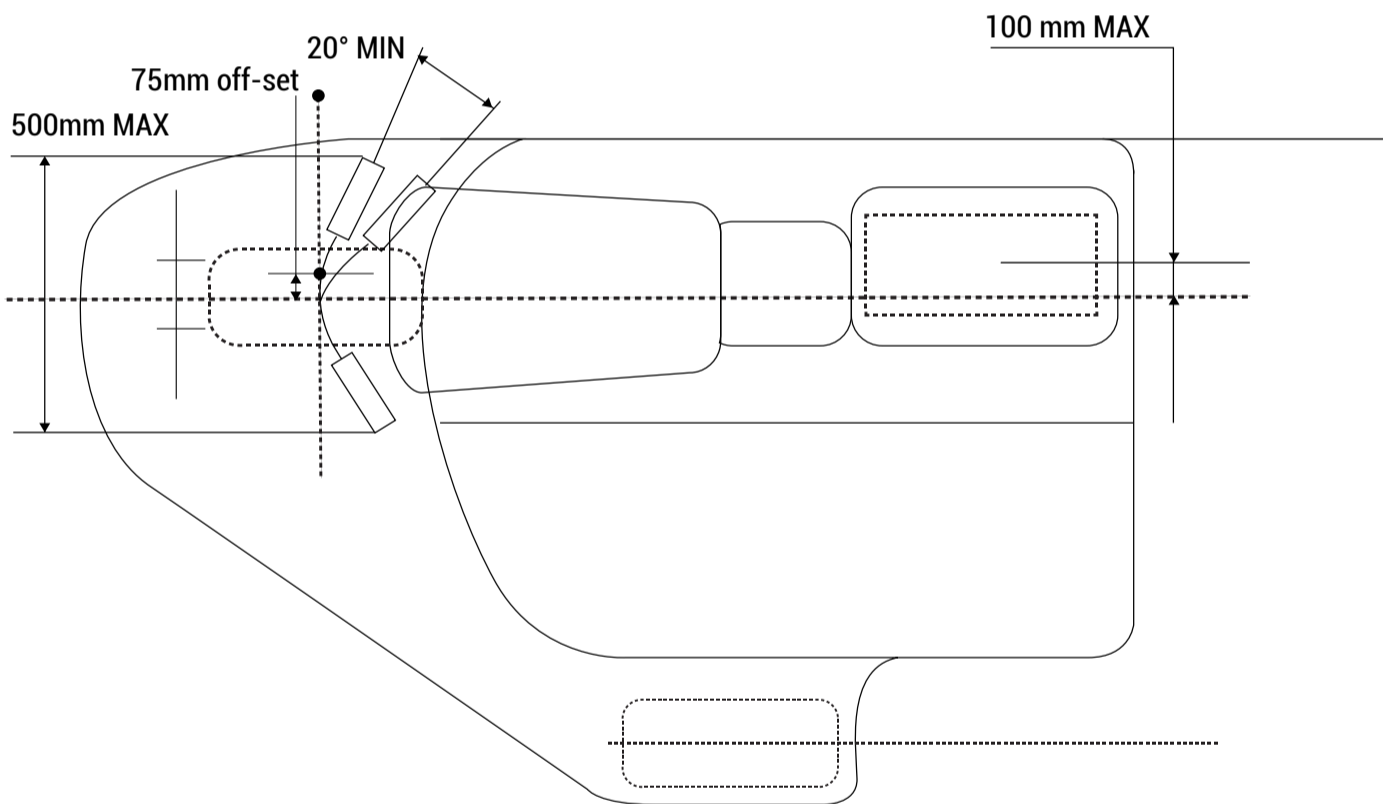
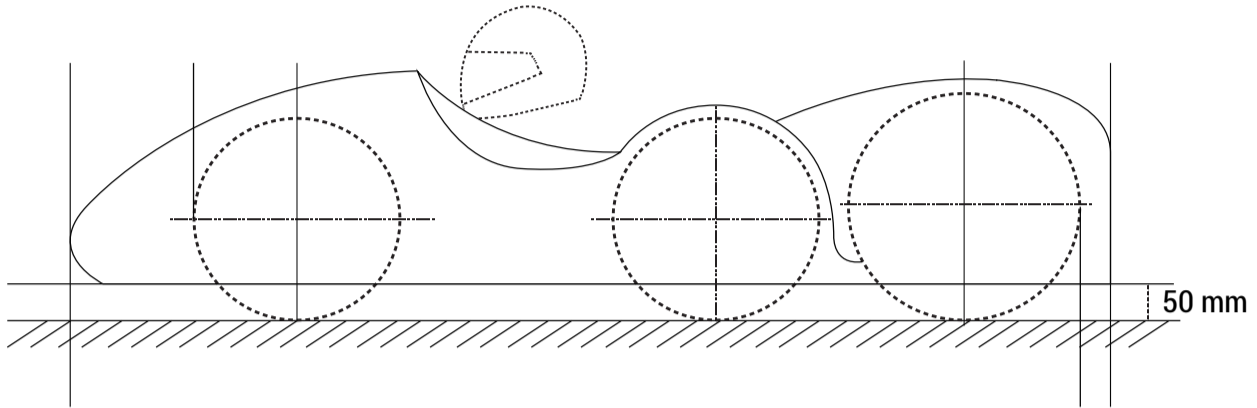

DIAGRAM C



# DIAGRAM D



# DIAGRAM E

## NUMBERS

